



MEEK MIRRORS, LLC
 PO Box 11200
 Fort Smith, Arkansas 72917-1200
 800-643-2533 Fax 479-646-6231
www.meekmirrors.com

**Architectural
 Specification**

STAINLESS STEEL CHANNEL FRAMED MIRROR M1500 Bright Finish M1510 Satin Finish	DATE 2/2010	MODEL M1500 M1510	SHEET NO. 2-01
---	----------------	-------------------------	-------------------

MODEL M1500/M1510 STAINLESS STEEL CHANNEL FRAMED MIRROR

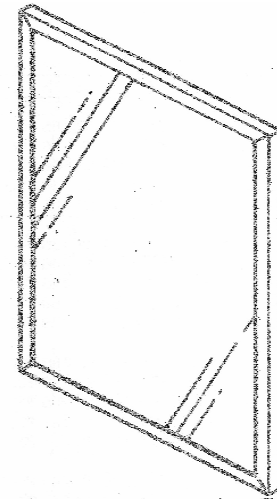
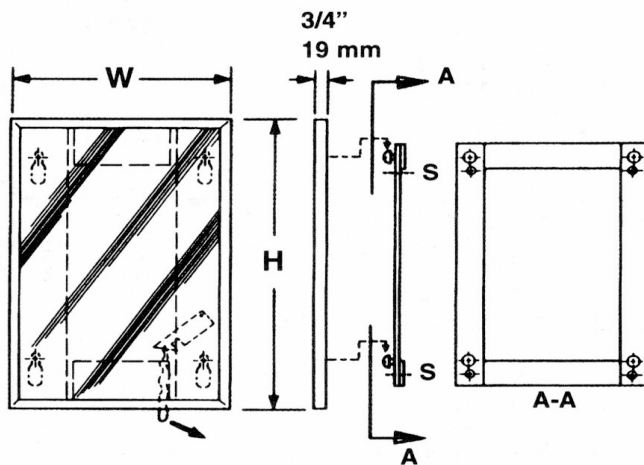

MIRROR: No.1 quality 1/4" (6mm) thick float glass mirror, electrolytic copper back, guaranteed for 15 years against silver spoilage. Other glazes available.

MIRROR PROTECTION: Protected by shock-absorbing expanded polystyrene sheets.

WALL HANGER: 22 Gauge (.76mm) quality corrosion-resistant galvanized steel strips with precision punched holes in support areas.

BACK PLATE: 22 Gauge (.76mm) lock forming quality corrosion-resistant galvanized strips with precision punched holes for quick, easy installation.

FRAME: Channel frame, 9/16"x9/16"x9/16" (14mm x 14mm x 14mm), is constructed from a type 430, 20 gauge stainless steel with mitered corners in bright polished finish. Satin finish optional.

INSTALLATION: Install wall plate, fasten all four corners. Center mirror over wall plate, slide down to hook, check all four corners. Pull string toward corner to lock. After final inspection, cut and remove string.

GUARANTEE: Meek Mirrors gives a one year guarantee on all of their products against defects in workmanship and material.

SPECIFICATION: Product shall be Model M1500 or M1510 as manufactured by Meek Mirrors Fort Smith, Arkansas. Above data is applicable to productions as of the date of this technical data sheet. The manufacturer reserves the right to make changes in design without formal notice.